





Exercise helps cancer patients
live longer - Latest finding about
colon cancer published

[https://www.npr.org/2025/04/07/nx-s1-5323814/
exercise-colon-cancer-longevity](https://www.npr.org/2025/04/07/nx-s1-5323814/exercise-colon-cancer-longevity)

{ NPR
radio
story

Hückel's Aromaticity Criteria

- 1) All ring atoms are sp^2 (they have a 2p orbital)
- 2) Flat (so the 2p orbitals overlap)
- 3) Monocyclic (Rule 4) only applies to single rings)
- 4) $4n+2$ pi electrons (2,6,10,14....)

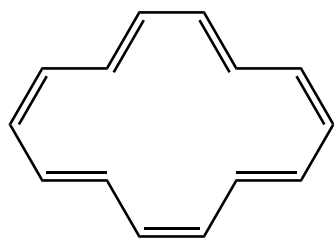
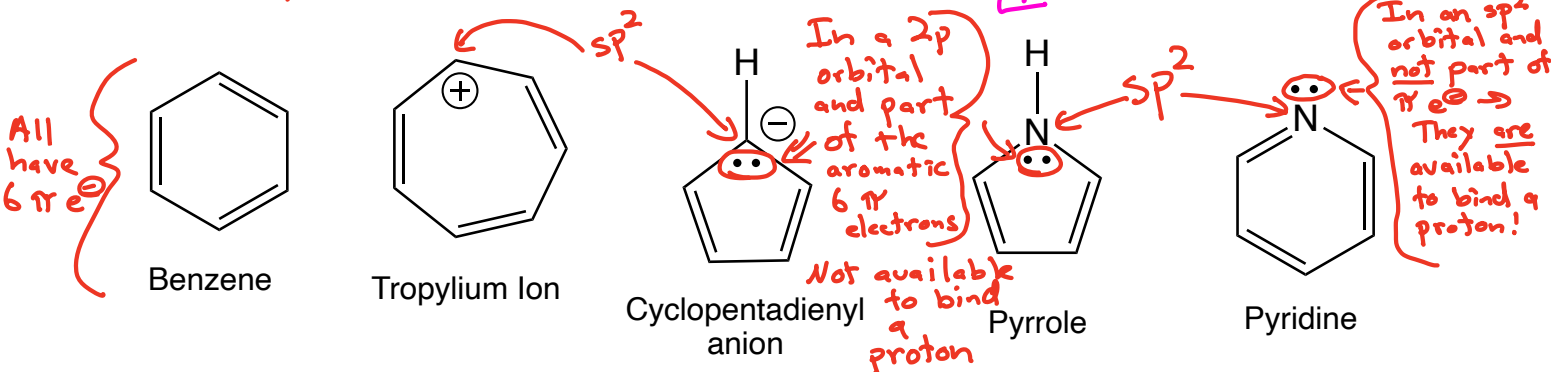

Annulene

14 π electrons

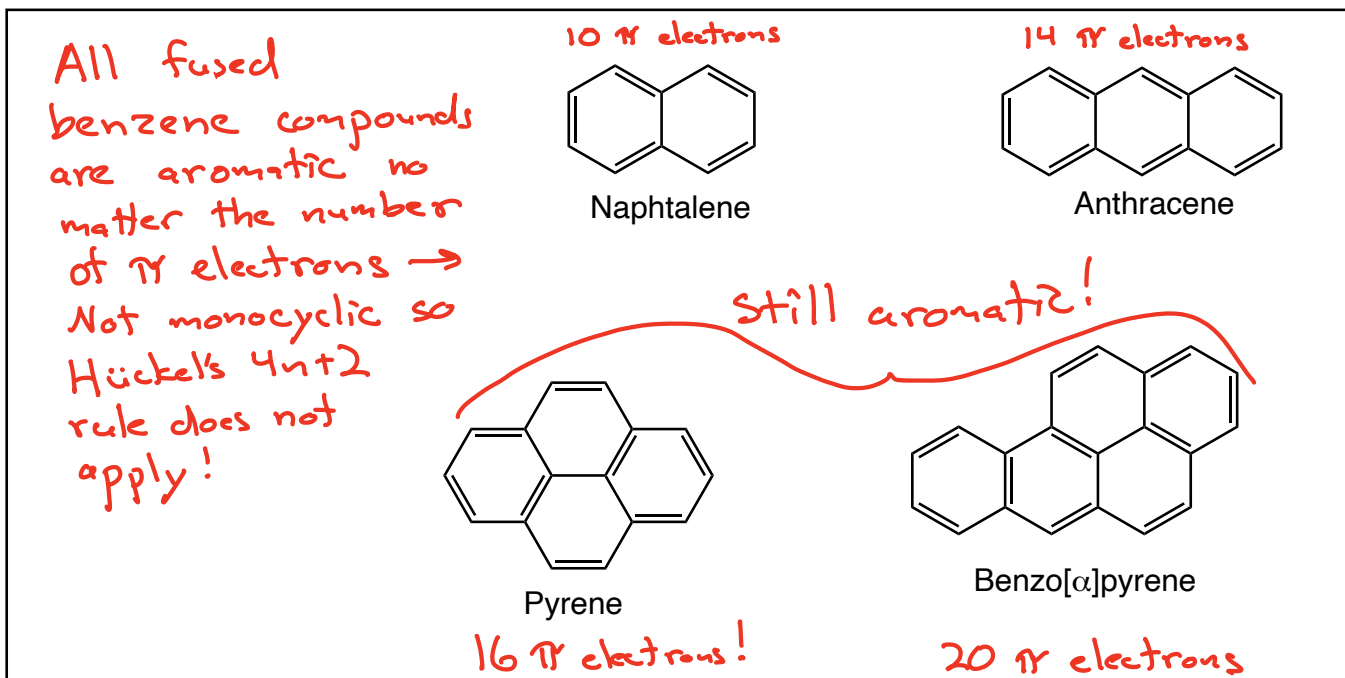
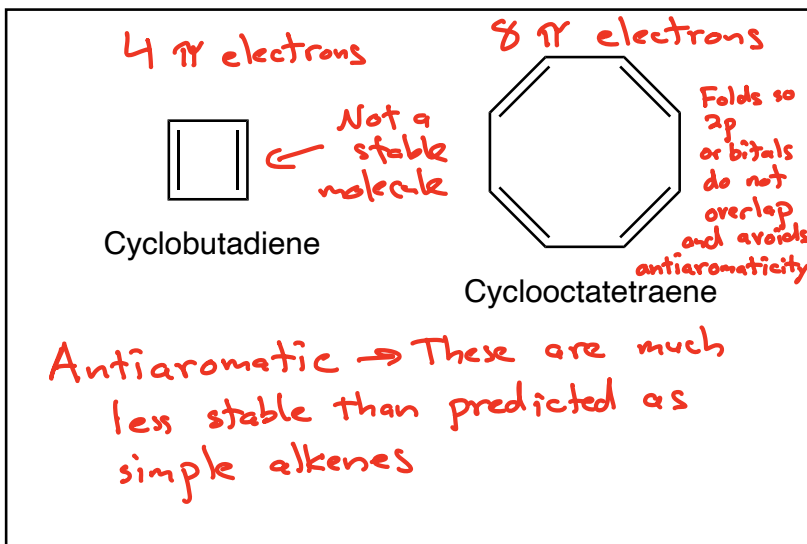

Organic Chemistry is the study of carbon-containing molecules. This class has two points.

The first point of the class is to understand the organic chemistry of living systems. We will teach you how to think about and understand the most amazing molecules on the planet!!

You will learn how MRI scans work. 1/16/25

You will learn the basic principles of pharmaceutical science and how many drugs work. 1/21/25

You will learn about the special bond that holds carbohydrates such as glucose in six-membered rings, connects carbohydrate monomers together to make complex carbohydrate structures and is critical to DNA and RNA structure. 1/30/25

You will learn how soap is made from animal fat and how it works to keep us clean. 2/25/25

You will learn the important structural reason proteins, the most important molecular machines in our bodies, can support the chemistry of life. 2/18/25 AMIDE DAY!

You will learn how important antibiotics like penicillins work, including ones that make stable covalent bonds as part of their mode of action. 4/1/25

You will learn why carrots are orange and tomatoes are red. 4/1/25

You will learn the very cool reason that the DNA and RNA bases are entirely flat so they can stack in the double helix structure.

You will learn how energy drinks work.

You will learn even more about why fentanyl is such a devastating part of the opioid problem and how Naloxone is an antidote for a fentanyl overdose.

You will learn even more details about why Magic Johnson is still alive, decades after contracting HIV, and how the same strategy is being used to fight COVID.

You will learn about the surprising chemical reason the Pfizer and Moderna mRNA vaccines elicit strong immune responses.

The second point of organic chemistry is the synthesis of complex molecules from simpler ones by making and breaking specific bonds, especially carbon-carbon bonds.

You will learn how carbon-metal bonds lead to new carbon-carbon bonds. 1/16/25

You will learn how most reactions of carbonyl compounds involve only the four common mechanistic elements operating in only a few common patterns. 1/21/25

You will learn how, by simply adding a catalytic amount of base like HO^- to aldehydes or ketones, you can make new carbon-carbon bonds, giving complicated and useful products. 2/27/25 2/16/25

You will learn a reaction that can convert vinegar and vodka into a common solvent. Fischer esterification!
Acetic acid \downarrow Ethanol \downarrow
Ethyl acetate \rightarrow

You will learn why molecules with six-membered rings and alternating double bonds are stable. 4/3/25

You will learn a reaction that can turn model airplane glue into a powerful explosive.

Most important, you will develop powerful critical thinking skills:

1. You will learn how to look at a molecule and accurately predict which atoms will react to make new bonds, and which bonds will break during reactions.
2. You will learn how to analyze a complex molecule's structure so that you can predict ways to make it via multiple reactions starting with less complex starting molecules.

Aromatic resonance stabilization of charged species

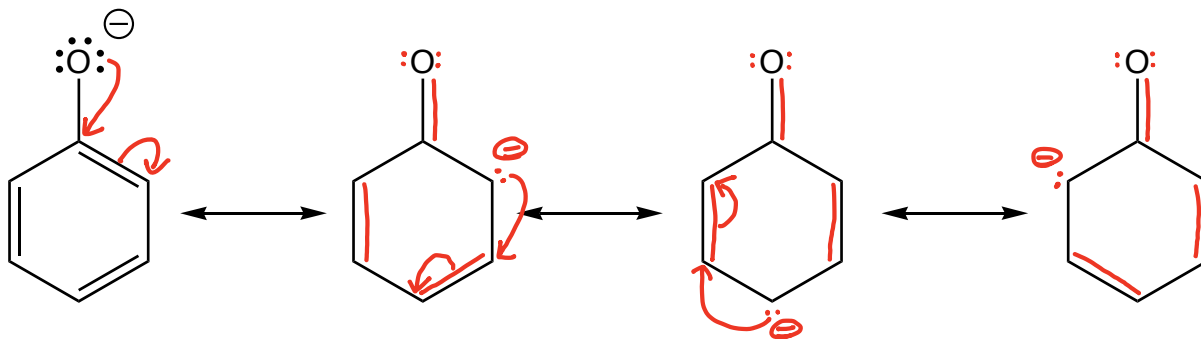

Phenoxide anion

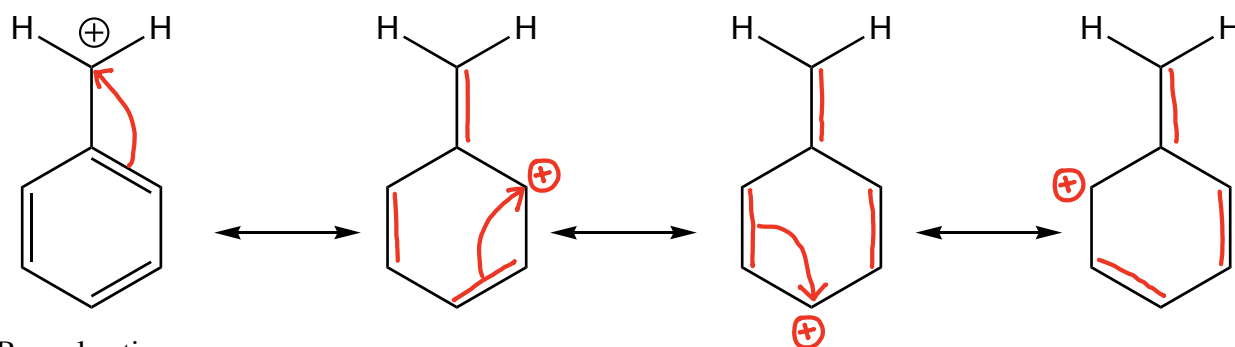

Benzyl cation

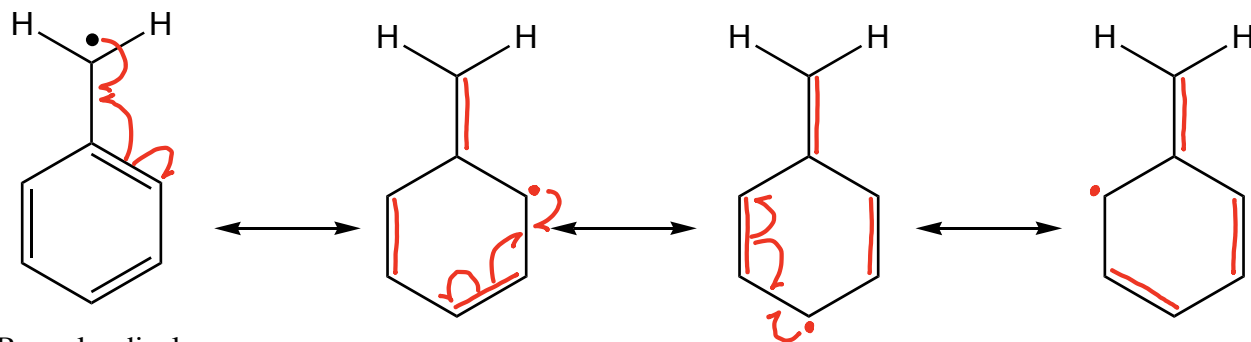

Benzyl radical

Important takeaways from the contributing structures

- 1) Benzene rings stabilize anions, cations and radicals (Golden Rules 5, 6 and 7)
- 2) Molecules can have electrons on an atom outside the ring delocalized into the π system and the "extra" electrons do not count against the $4n+2$ number of π electrons

Summary \rightarrow Molecules like those below are all highly stabilized by delocalization into the benzene ring.

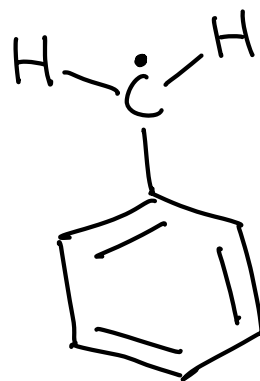
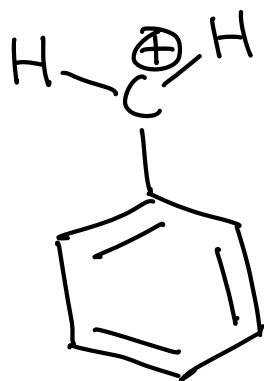
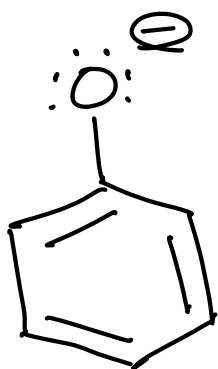

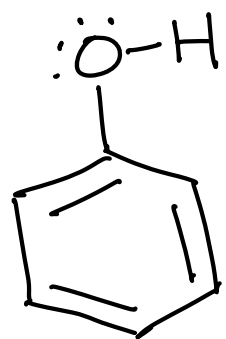

Phenol

$pK_a = 9.95$

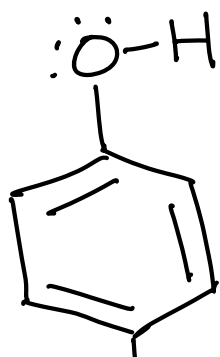

Cl

$pK_a = 9.0$

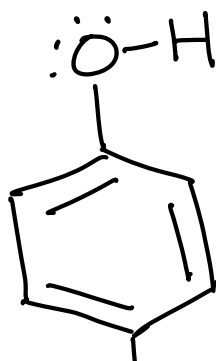

NO_2

$pK_a = 7.15$

Very electron withdrawing and called a nitro group

Relative acidity \rightarrow

Electron withdrawing groups on the ring stabilize the deprotonated anion, making OH group more acidic (Inductive effect)

Important terms

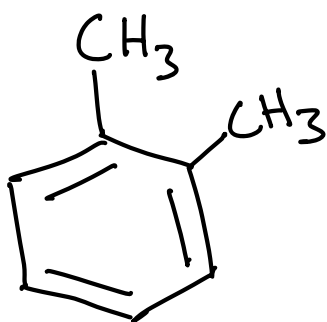

ortho

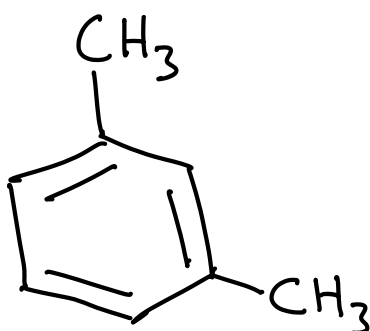

meta

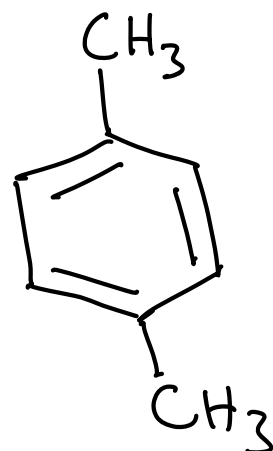

para

Benzyl vs. Phenyl

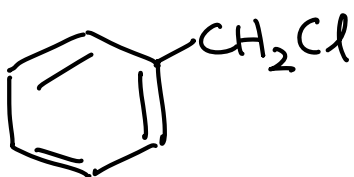

Benzyl chloride

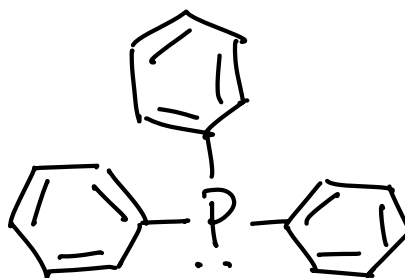

Triphenyl phosphine

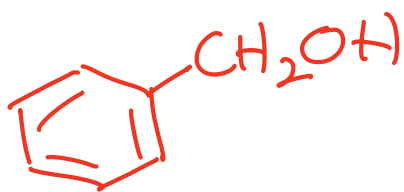

Benzyl alcohol

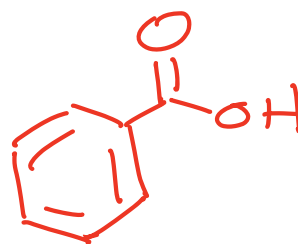

Benzoic acid

A carbon attached to a benzene ring has special reactivity so it has a special name - the benzylic carbon

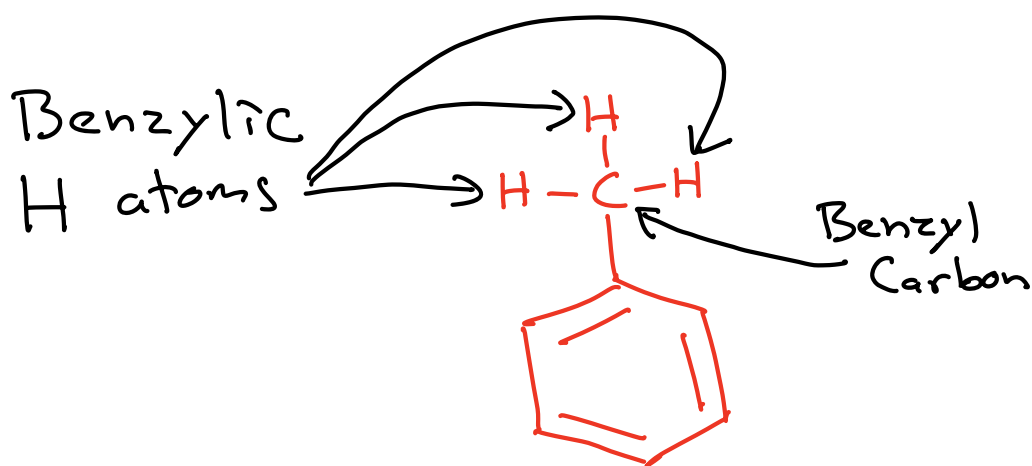

Free radical halogenation

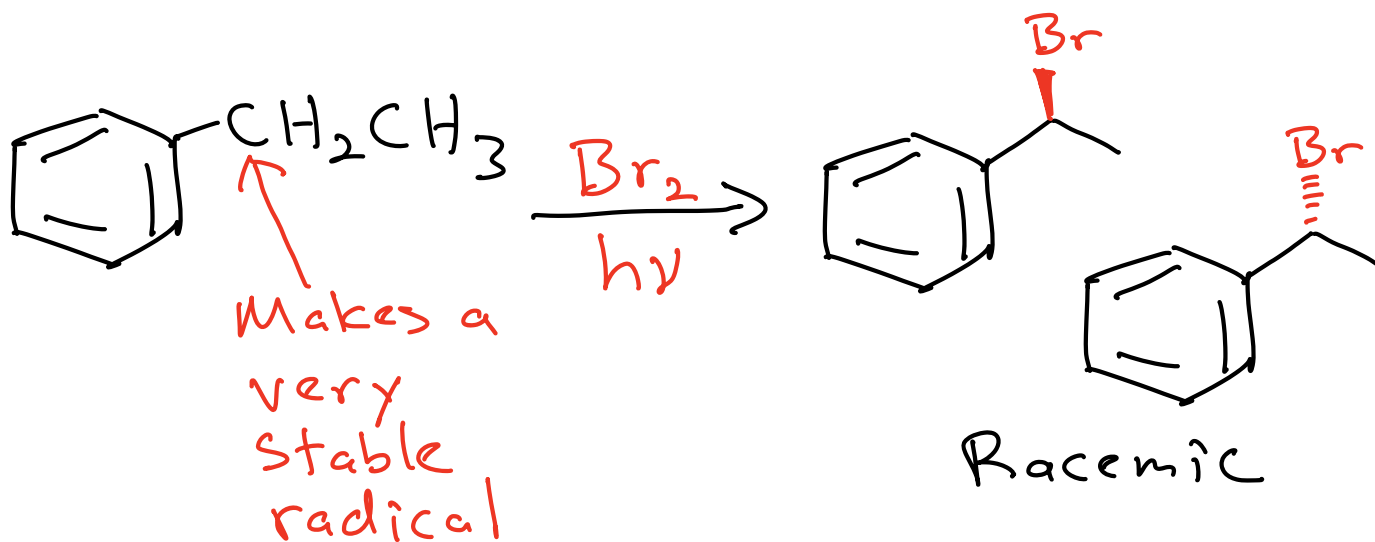

Radical Stability

Methyl < 1° < 2° < 3° < Benzylic Radical

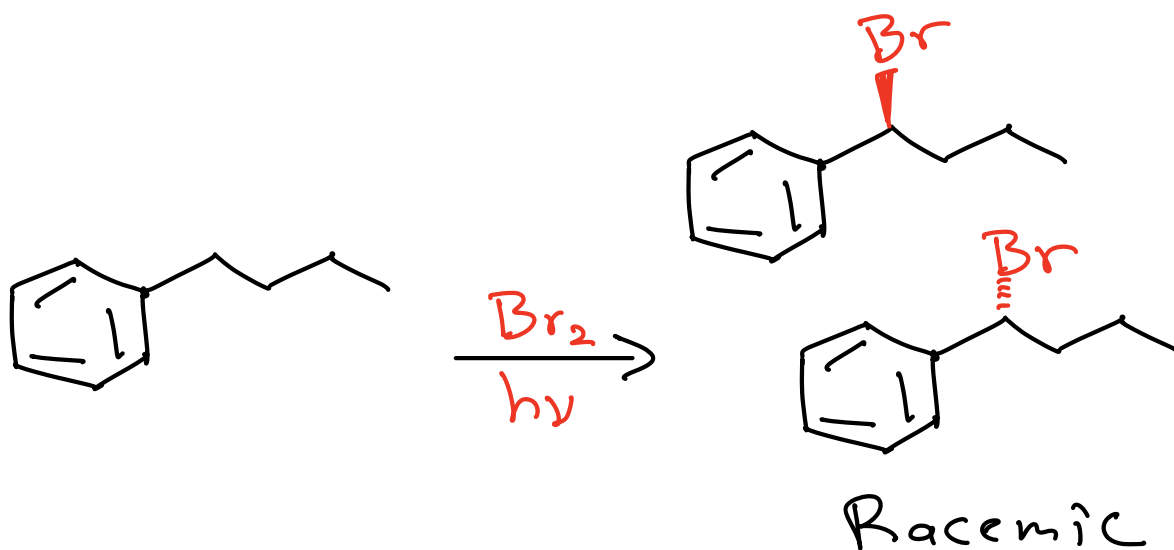

Oxidation

The benzylic carbon is easy to oxidize all the way to a carboxylic acid — even breaking C-C bonds!

The benzylic carbon needs at least one H atom for the reaction to occur

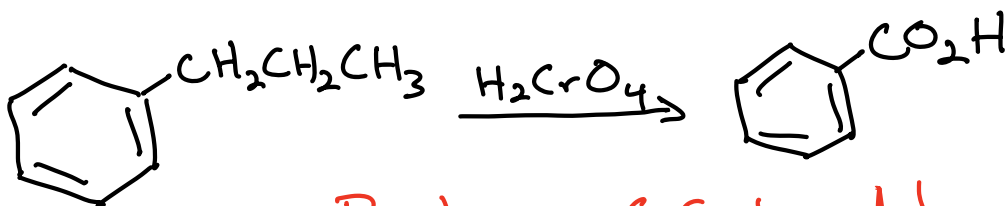
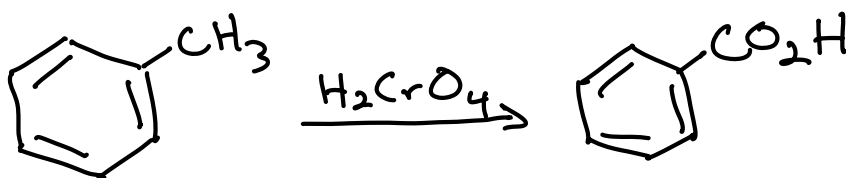

Broke a C-C bond!

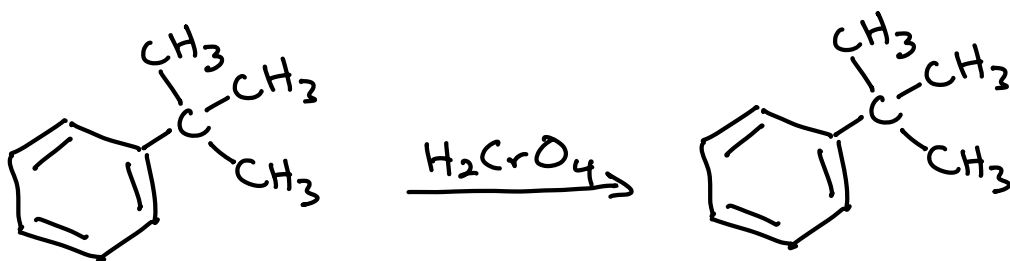

No C-H bond on benzylic C atom

(NO REACTION)

Wicked Strong Electrophile

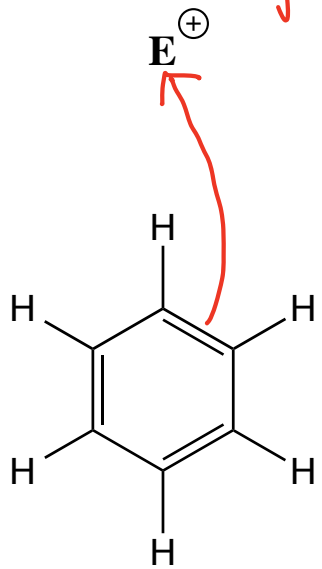

Weak Nucleophile

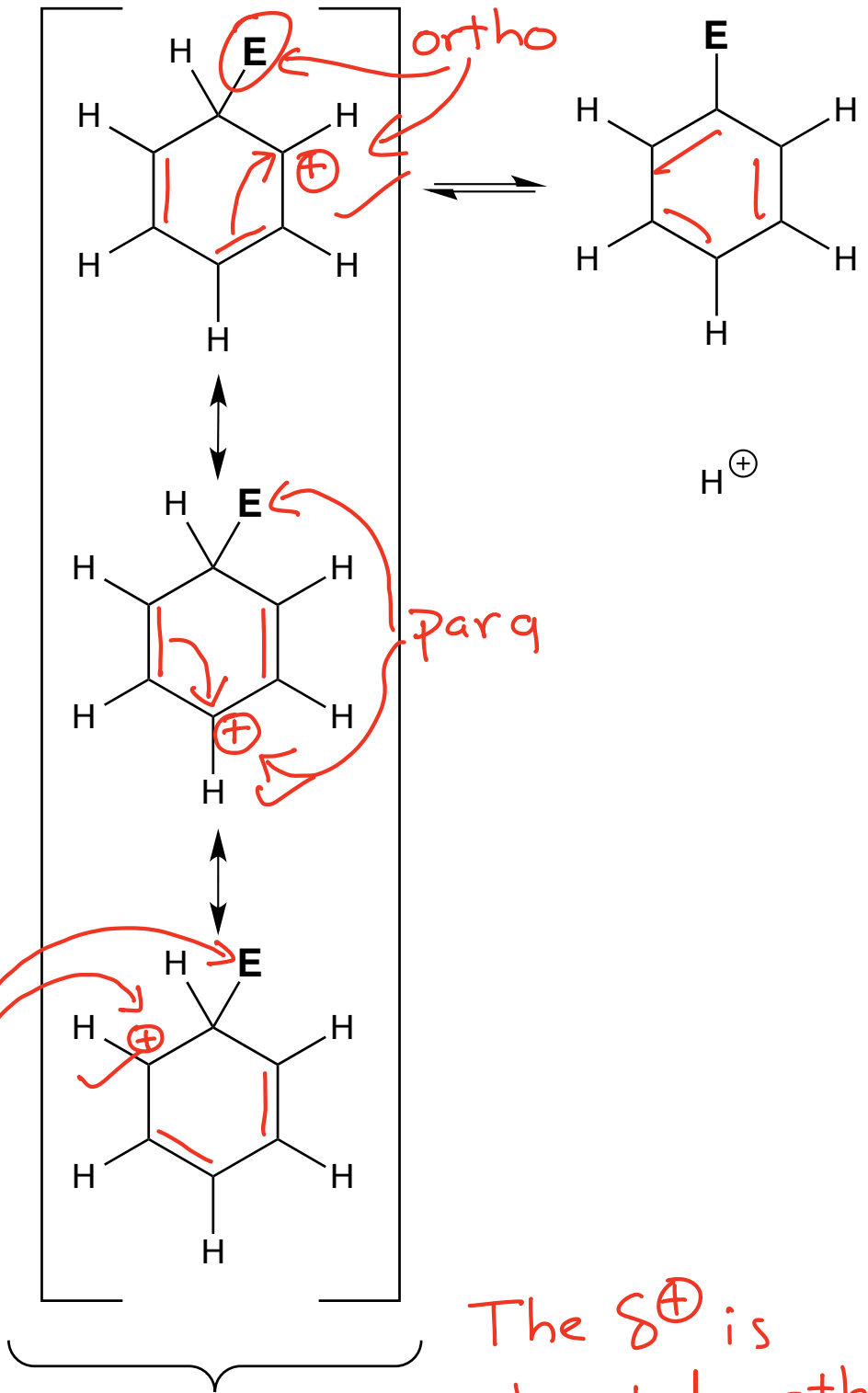
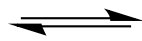

Called the Arenium Ion

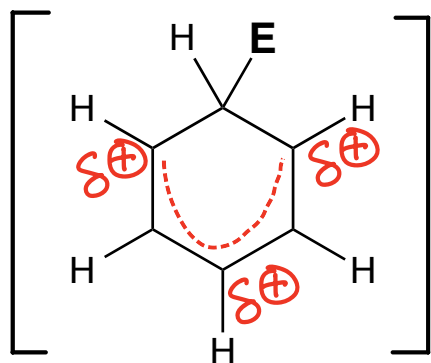

The δ^+ is located ortho and para to where the new bond to "E" is located

Summary → Wicked strong electrophile reacts with the benzene π electron density to make a resonance delocalized arenium ion intermediate that loses a proton to give a substituted benzene

The arenium ion intermediate has partial \oplus charge ortho and para to the new bond to E

This reaction is called "Electrophilic Aromatic Substitution (EAS)"

Reagents

Halogenation X_2, FeX_3

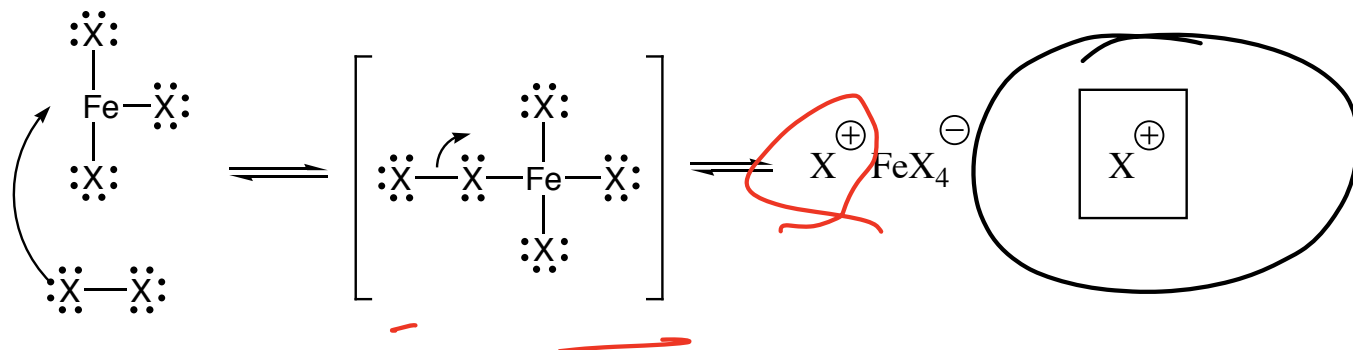

$X = Br, Cl$

Nitration H_2SO_4/HNO_3

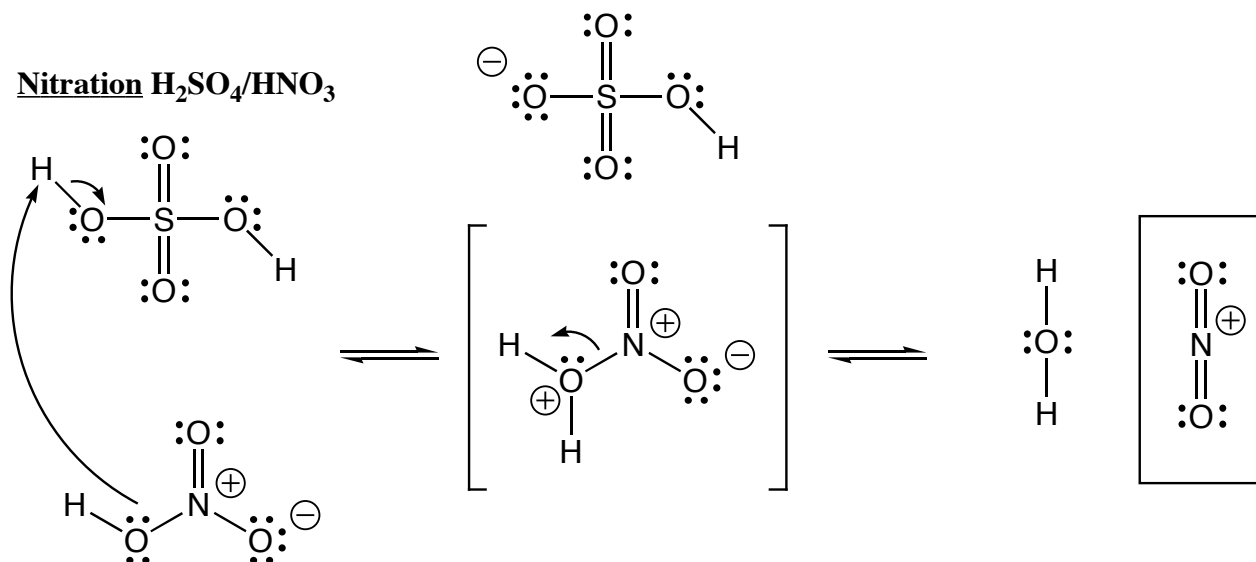

Sulfonation H_2SO_4/SO_3

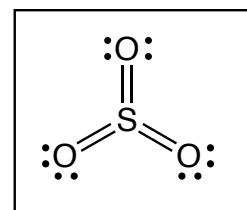
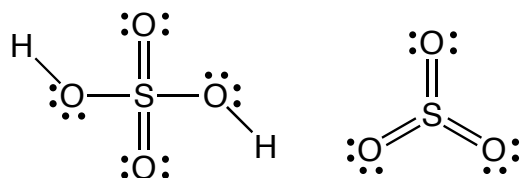

Fuming sulfuric acid contains both of the above reagents, the SO_3 is the important one

Reagents

Friedel-Crafts Alkylation $R-X, AlX_3$

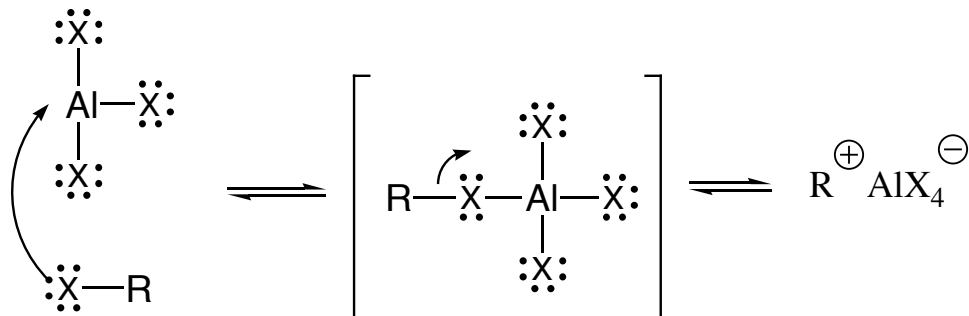

$X = Br, Cl$

Wicked strong
electrophile

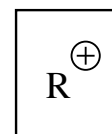

Note this is a carbocation, so it will rearrange if it is a primary or a rearrangement-prone secondary cation

Friedel-Crafts Acylation $RCOCl, AlCl_3$

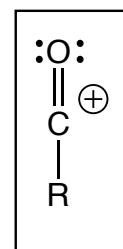
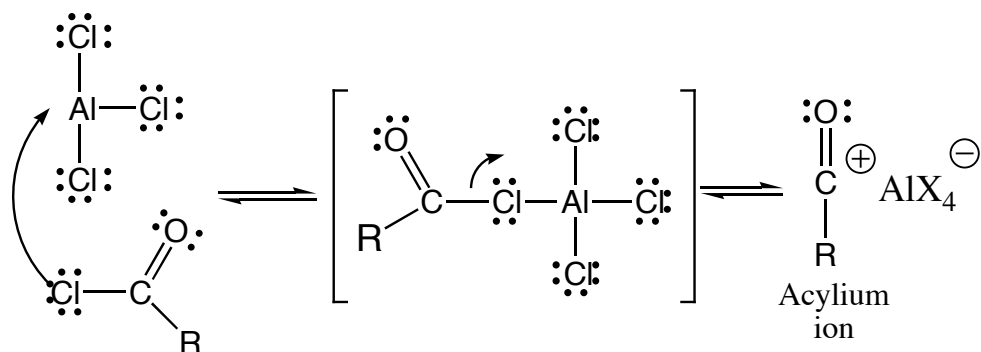

Other notes: 1) It is hard to stop the Friedel-Crafts alkylation after one alkyl group adds (because alkyl groups are "good", that is, activating), but it can be done. 2) Neither Friedel-Crafts reaction works if there is already an electron withdrawing (bad) group on the ring.

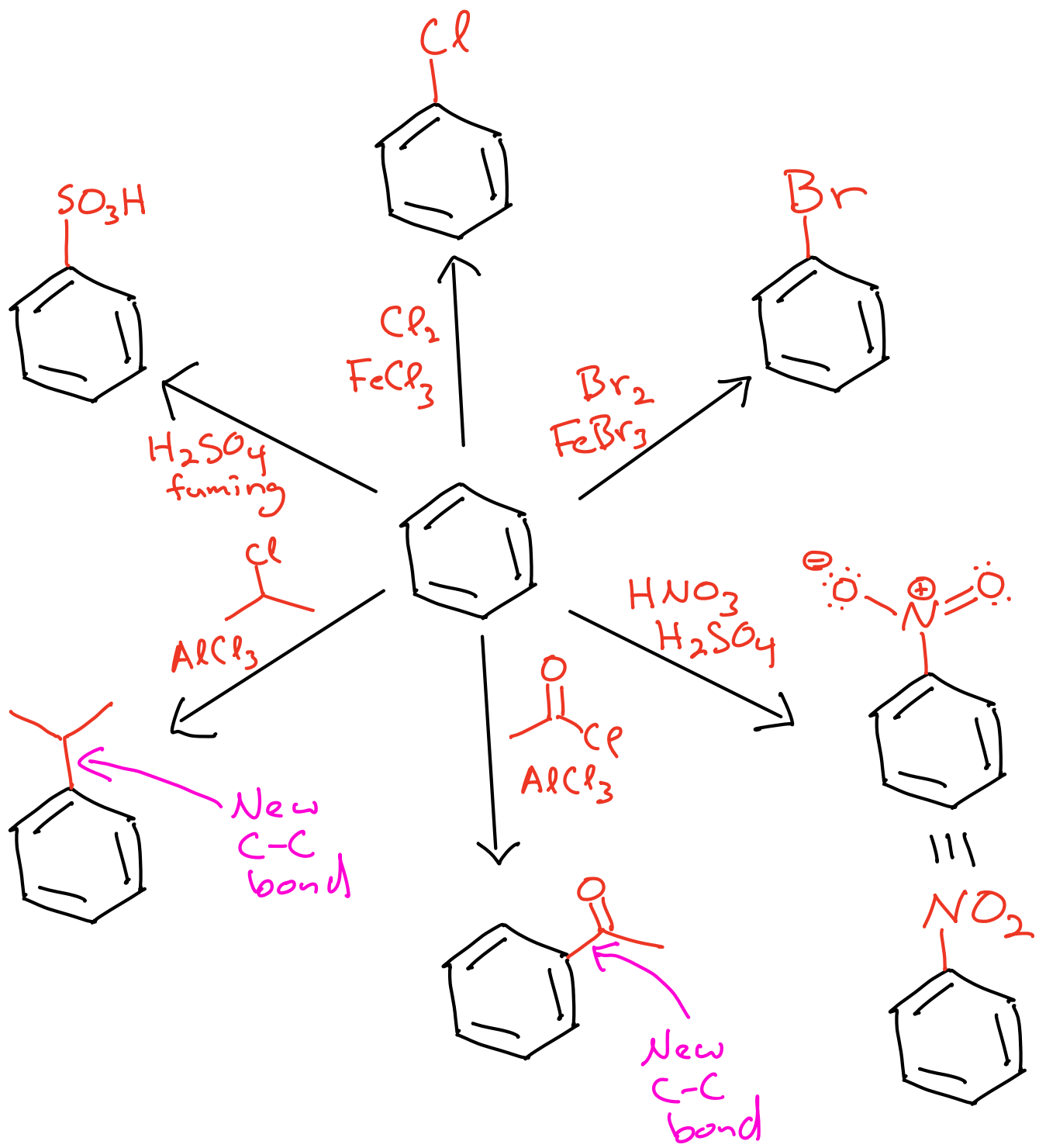

Friedel-Crafts Alkylations

Issue #1 → Carbocations rearrange!

Cannot use primary haloalkanes — they always rearrange!

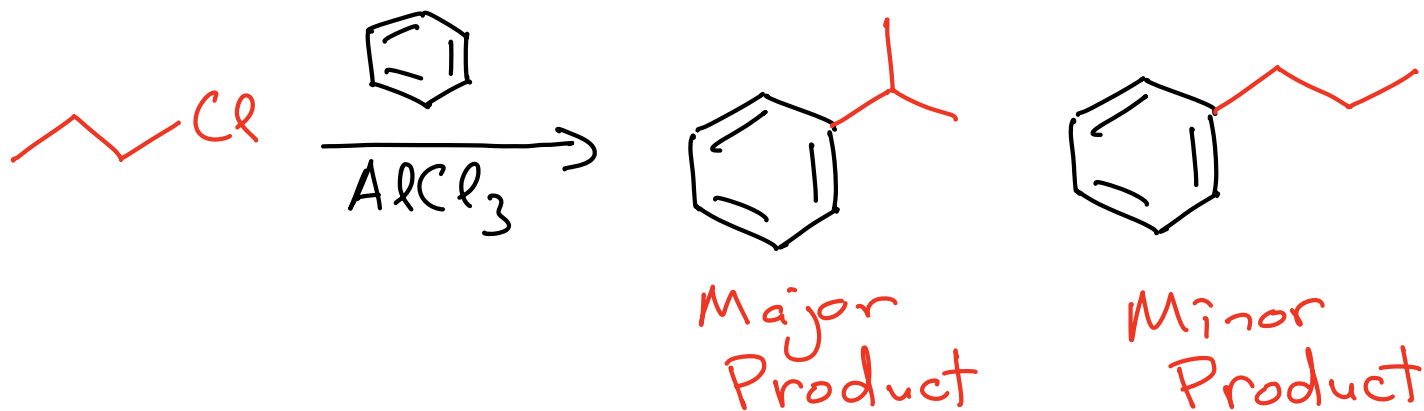
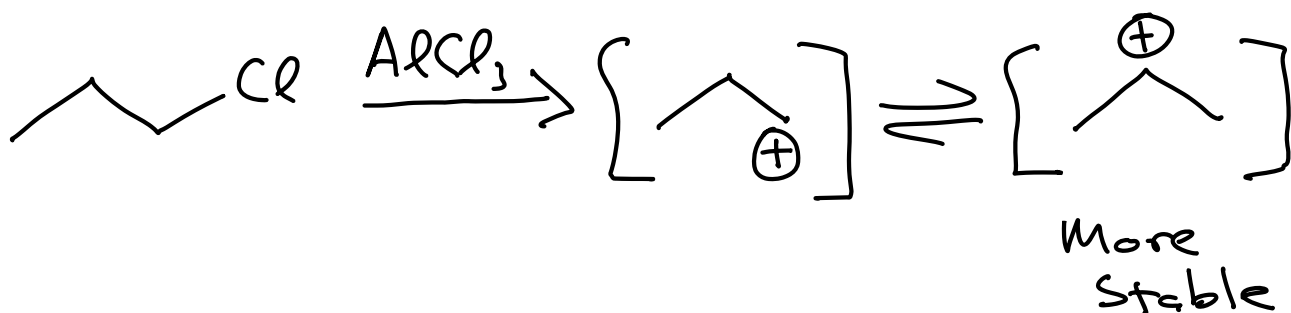

Workaround for primary alkyl group

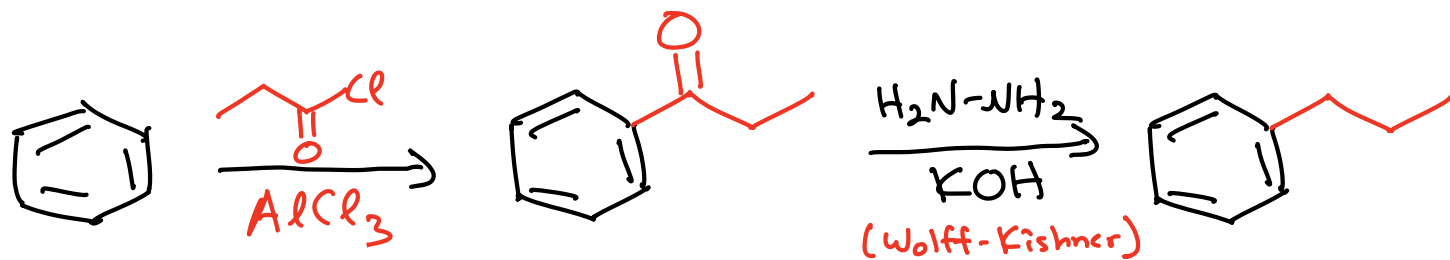

* Acylium ions do NOT rearrange!

Issue #2 → Time capsule: Alkyl groups are GOOD groups, so it is difficult (but not impossible) to stop at the addition of one alkyl group.

Issue #3 → Time capsule: Neither the Friedel-Crafts alkylation or acylation will work if there is a BAD (deactivating) group already on the ring



THE GOOD, THE BAD AND THE UGLY (1966)



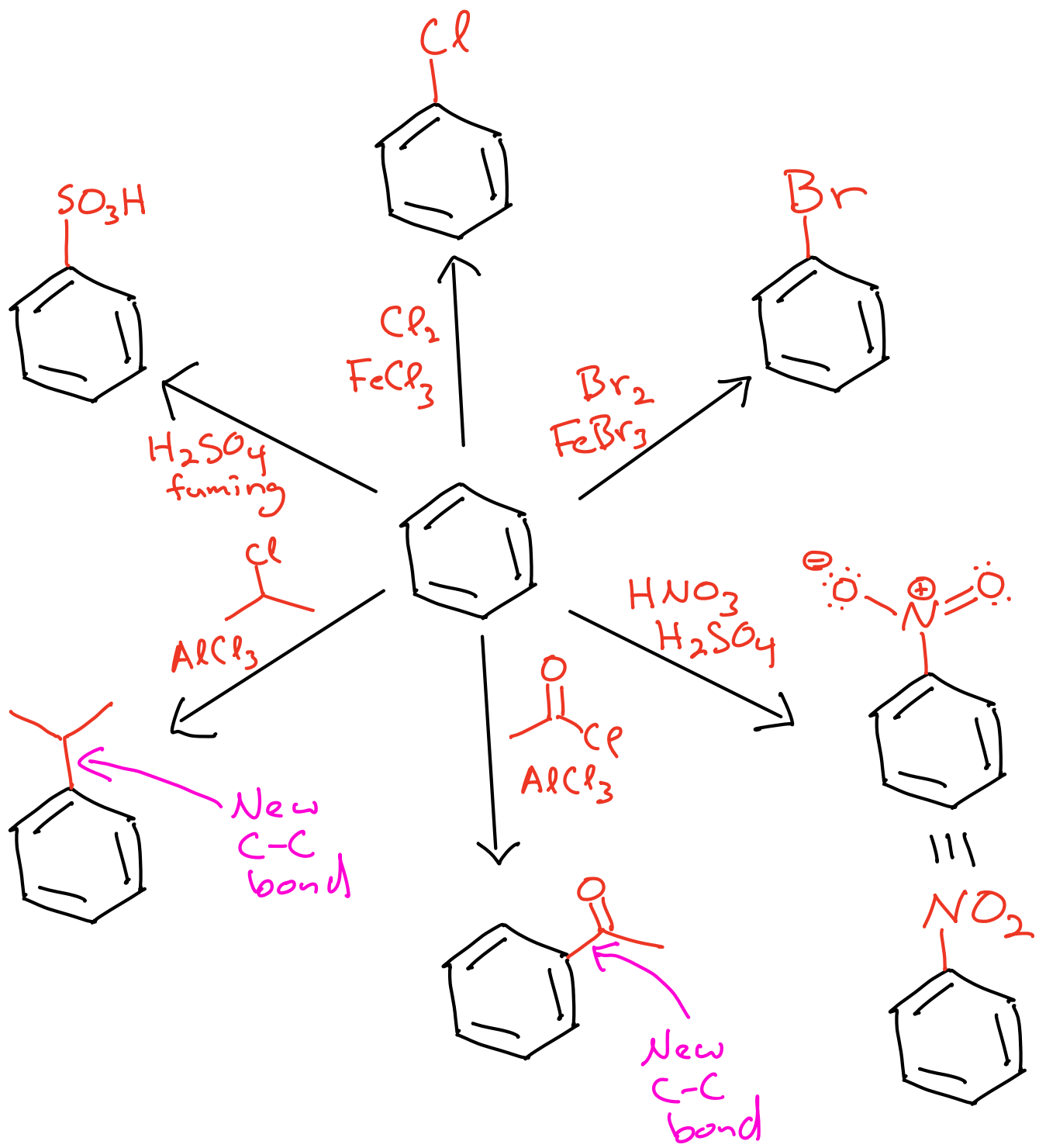

Wicked Strong Electrophile

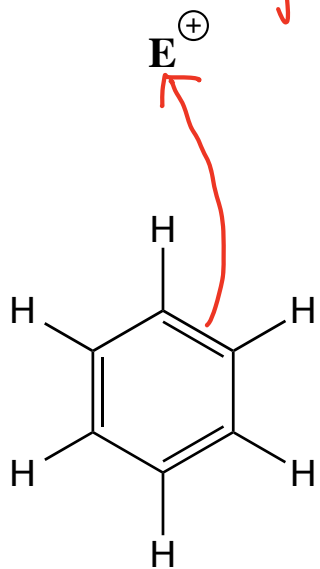

Weak Nucleophile

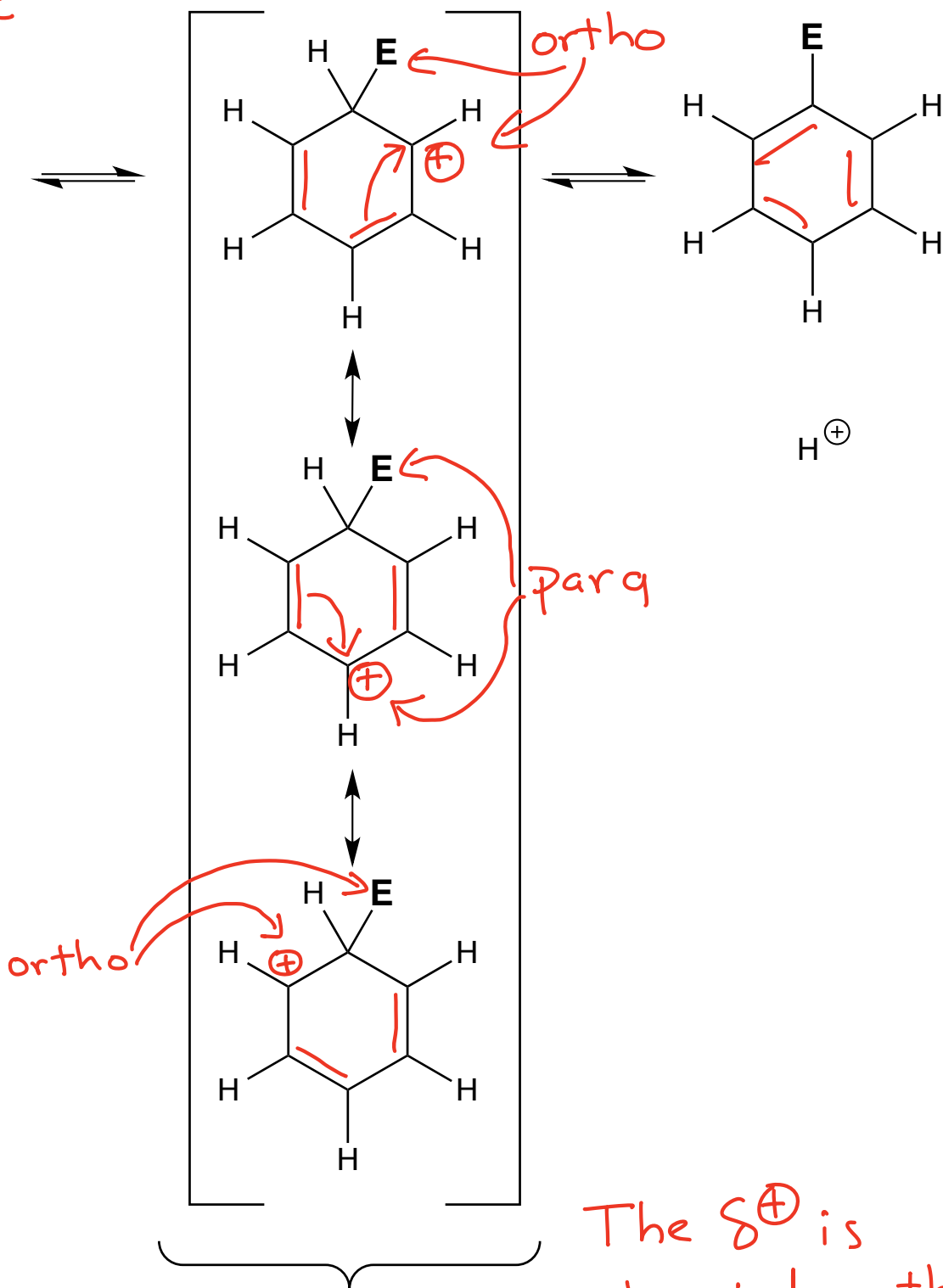
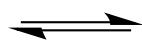

Called the Arenium Ion

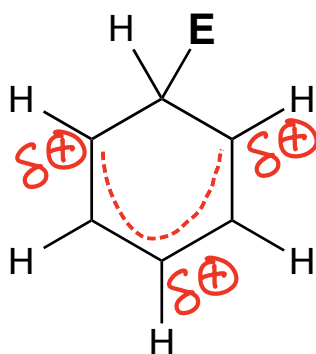

The δ^+ is located ortho and para to where the new bond to "E" is located

Arenium ion *stabilizing* interactions ← GOOD

A) **Pi donation**, a resonance effect for atoms with lone pairs attached to the ring

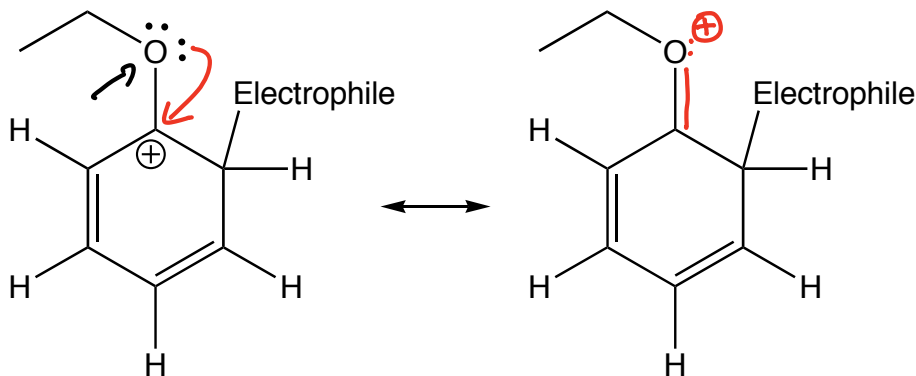

✓ ← "pi-pi"
↑
The "Greek interactions"
↓
"sigma-pi"

B) **Hyperconjugation** for alkyl groups attached to the ring

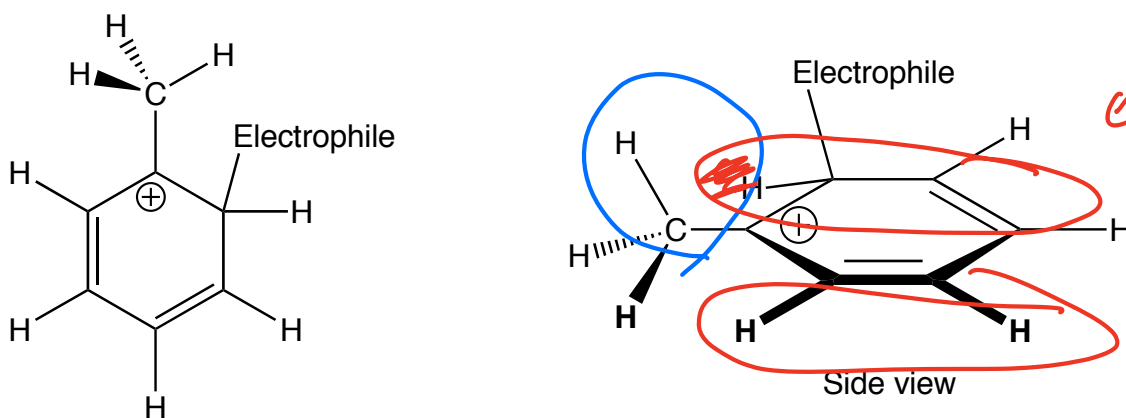

Arenium ion *destabilizing* interaction ← BAD

A) **Inductive effect** of electronegative atoms or groups attached to the ring

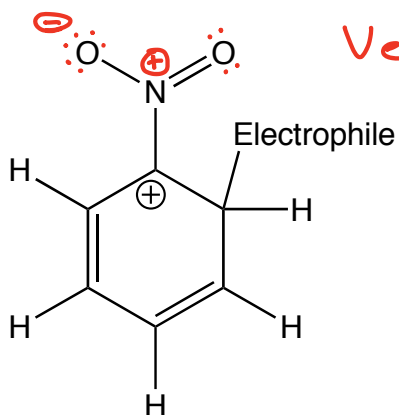

Very electron withdrawing